

## National Masonry Instructors Association

- Platinum Sponsor \$750.00
- Gold Sponsor \$500.00
- Silver Sponsor \$350.00

Yes! I/We want to support the National Masonry Instructors Association by contributing \$\_\_\_\_\_ for developmental costs.

Yes! I/We want to support the National Masonry Instructors Association by joining with the Industry Membership/Associate Membership. Annual Membership dues for \$50.00 are enclosed.

### Sponsor Information

Company/Individual Sponsor: \_\_\_\_\_

Contact: Mr. Mrs. Miss \_\_\_\_\_

Street Address: \_\_\_\_\_

City/State/Zip: \_\_\_\_\_

Phone: \_\_\_\_\_ Fax: \_\_\_\_\_

E-Mail: \_\_\_\_\_

### Membership Form NMIA

Name: \_\_\_\_\_

Home Address: \_\_\_\_\_

City/State/Zip: \_\_\_\_\_

School: \_\_\_\_\_

Address: \_\_\_\_\_

City/State/Zip: \_\_\_\_\_

Home Phone: \_\_\_\_\_ Home Fax: \_\_\_\_\_

School Phone: \_\_\_\_\_ School Fax: \_\_\_\_\_

● **Make checks payable to/Mail to: National Masonry Instructors Association; PO Box 669, Stevensville, MD 21666** ●

### Upcoming Events

June	25-29	SkillsUSA National Conference Louisville, Kentucky	October 17-19	Hardscape North America Expo Louisville, Kentucky
July 31 - Aug 3		NCMA Mid-Year Meeting Chicago, Illinois	January 20-25	MCAA Annual Convention World of Concrete Las Vegas, Nevada
Sept	24-26	MCAA Mid-Year Meeting Austin, Texas		



# National Masonry Instructors Association

## Letter from the President

Dear NMIA members, business partners and sponsors,

The National Masonry Instructors Association has been in existence for 29 years. Its mission is to develop a collaborative partnership with the education community, business and industry. The NMIA create an awareness of the masonry occupation by helping instructors collaborate with each other on recruiting, teaching method, new technology, developing partnership with business and industry to enhance the quality of our student education. The goals of NMIA is to improve curriculum and teaching material, upgrade our method of recruitment, helping instructors to create a national wide bond between all masonry instructors and to help promote masonry career tech centers throughout the United States.

The NMIA annual conference will be held on July 8th- 11th 2018 this year. Where the instructors will be afforded the opportunity to learn new masonry techniques, new tools and equipment, new ways of building fireplaces and new types of bricks that are coming out in the industry. Also, this will allow instructors to network with other instructors across the United States.

The conference will be held at the Hampton Inn Gulf Shores located at 1701 Gulf Shores Parkway, Gulf Shores, AL 36542. Please come join us as we celebrate 29 years of helping masonry instructors achieve the goals of developing our youth.

Sincerely Yours,  
Jeffery Lee Mackie

### Mission Statement

The National Masonry Instructors Association's mission is to develop collaborative partnership with the education community, business and industry to create awareness of the professionalism of the masonry occupation by promoting quality masonry programs and keeping members informed of innovative trends and changing technology.

### NMIA Goals and Objectives

- Promoting masonry training programs throughout the United States
- Assist in the unification of masonry programs
- Improving curriculums and teaching materials
- Upgrading recruitment and training methods
- Increasing partnership with business and industry
- Promote annual workmanship and seminar for professional development

### Purpose

- To promote effective articulation between professional educators and business and industry.
- To provide comprehensive seminars, workshops and masonry specialists from all over the construction industry to share ideas, techniques and solutions for future success.
- To teach skills to increase performance and productivity.



# Contractor's Corner

# 2017 Conference St. Augustine, Florida

The National Masonry Instructors Association is celebrating 29 successful years of training and masonry promotion for the craft instructors of our industry. I have been fortunate and privileged to be associated with the knowledgeable and experienced Masonry Instructors within this organization. As an industry member I have attended many summer conferences which provided useful information allowing attendees to stay current on masonry practices.

Seminars that are available during the summer conference cover a wide range of topics presented by top industry professionals. This year James Holt from Prosoco Inc., will discuss the Sure Kleen product line and all the benefits. I will be discussing moisture management practices and cover the Mortar Net Solutions product line. Jeff Buczkiewicz, Masonry Contractors Association of America's (MCAA) president, will discuss what new programs and events that are ahead with the MCAA. Bill Kjolien with Argos, will discuss mortars and the importance is selecting the proper mortar for the material that you are constructing. Bill is an industry expert that can offer endless knowledge on any topic you can imagine. Al Herndon will discuss the exciting news from Florida Masonry and Apprentice & Education. Al always can offer an idea that can improve the training that you provide to all of your students. Ryan Coyne of Quikrete will present on masonry mortars. Ryan's knowledge and personality will educate you on useful science that is part of Quikrete's commitment to producing superior products for this industry. There will be many other topics discussed by experienced and knowledgeable presenters.

In 2016, Mortar Net Solutions became a lifetime sponsor of this organization to support the masonry instructors and the importance of corporate involvement in this organization. Sponsorships are important to this organization and I encourage everyone to consider becoming a proud sponsor of this organization.

Support for this organization must come from the manufacturers by donating money and materials to educate the student on the proper methods for using or installing their products. Contractors who desire a level of trained apprentice also benefit from supporting the instructors that train the personnel that will support them.

Sponsor form on back.

Steven Fechino  
Mortar Net Solutions



Moisture  
Management  
for Masonry

## Please Support Our Outstanding Supporters

- Mortar Net Solutions
- Bon Tool Company
- Henry Brick Company
- Carolina Concrete Masonry Association (CCMA)
- Brick Association of the Carolinas
- Brick Southeast
- Giant Cement Co.
- Holcim Cement Co.
- LaFarge Cement Company
- Mason Contractors Association of America (MCAA)
- McGee Brothers
- Brodie Contractors
- Marshalltown Tools
- Superior Clay Products
- Exact Match Masonry Staining
- Multiquip
- Spec Mix/Quikrete
- North Carolina Masonry Contractors Assc.



# 2018 MCAA Hall of Fame Inductee

## Curtis C. Hoover

Curtis C. Hoover started his career back in 1974, while still in high school. A new vo-tech center was opening called North Arundel Vo-Tech. This was just a technical school, which would be near the seven high schools in the north end of Anne Arundel County. He did not choose the masonry program. Instead, he signed up for the home improvement program. The related class for this program was masonry, a fact he did not know until second semester. After taking masonry that semester, he knew what he wanted to pursue for his career. Curtis fell in love with the class as it seemed to be natural for him.

Curtis C. Hoover started his career back in 1974, while still in high school. A new vo-tech center was opening called North Arundel Vo-Tech. This was just a technical school, which would be near the seven high schools in the north end of Anne Arundel County. He did not choose the masonry program. Instead, he signed up for the home improvement program. The related class for this program was masonry, a fact he did not know until second semester. After taking masonry that semester, he knew what he wanted to pursue for his career. Curtis fell in love with the class as it seemed to be natural for him.

Curtis' class was introduced to VICA (Vocational Industrial Clubs of America) known today as SkillsUSA. His first full year, he competed in the state VICA Masonry

Competition and placed fourth. In his senior year, he placed second and won a Silver Medal. This was the first medal ever won for his school. His dad had it placed in a frame, which currently he displays for all his students in hopes of encouraging them to do their best. Curtis wants them to know that they can accomplish anything if they work hard and put their minds to it.

Curtis started doing little masonry jobs while still in school, and was amazed by what kind of money one could make. He built his first fireplace at the age of 16, and was paid \$400.00 which helped him purchase a car. He officially started his career going out on work study his senior year for R.L. Walker and Sons, which was a residential masonry contractor. Most of the work was bricking up the front of houses, foundations and fireplaces. He worked for R.L. Walker for one and a half years.

Curtis always remained in contact with his masonry instructor. One day, they were talking when Curtis mentioned he wanted to get with a company that had benefits. His brother was a foreman for Henry J. Knott, Inc. which was one of the largest union masonry contractors in the Baltimore area. They hired Curtis in 1978. He started working as a bricklayer, then in 1982 he began as a foreman at the age of 25. Soon after the company began to grow and they were looking for an Assistant Superintendent, a job which included training new foremen

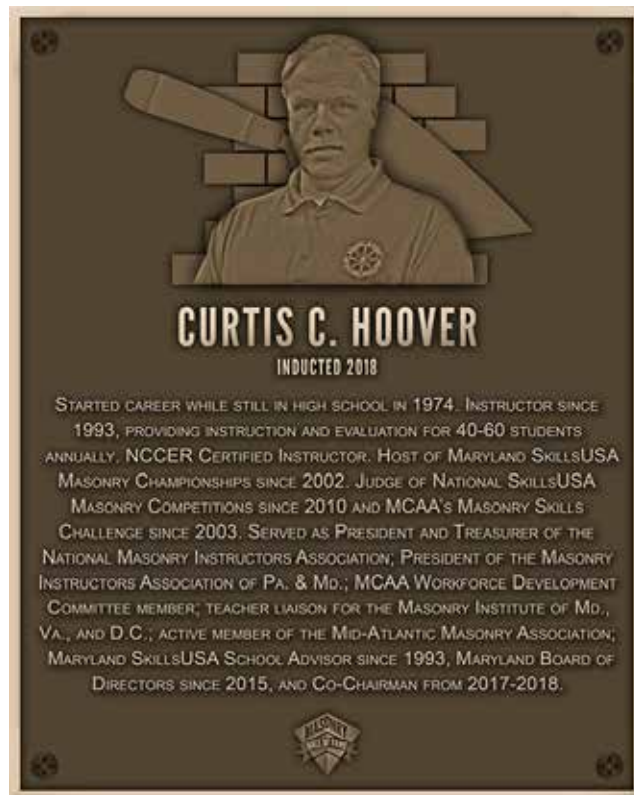

# SkillsUSA 2017



## Alabama State Competition



## Life long friends



## Please Support Our Outstanding Sponsors

- Mortar Net Solutions
- Bon Tool Company
- Henry Brick Company
- Carolina Concrete Masonry Association (CCMA)
- Brick Association of the Carolinas
- Brick Southeast
- Giant Cement Co.
- Holcim Cement Co.
- LaFarge Cement Company
- Mason Contractors Association of America (MCAA)
- McGee Brothers
- Brodie Contractors
- Marshalltown Tools
- Superior Clay Products
- Exact Match Masonry Staining
- Multiquip
- Spec Mix/Quikcrete
- North Carolina Masonry Contractors Assc.

# World of Concrete 2017

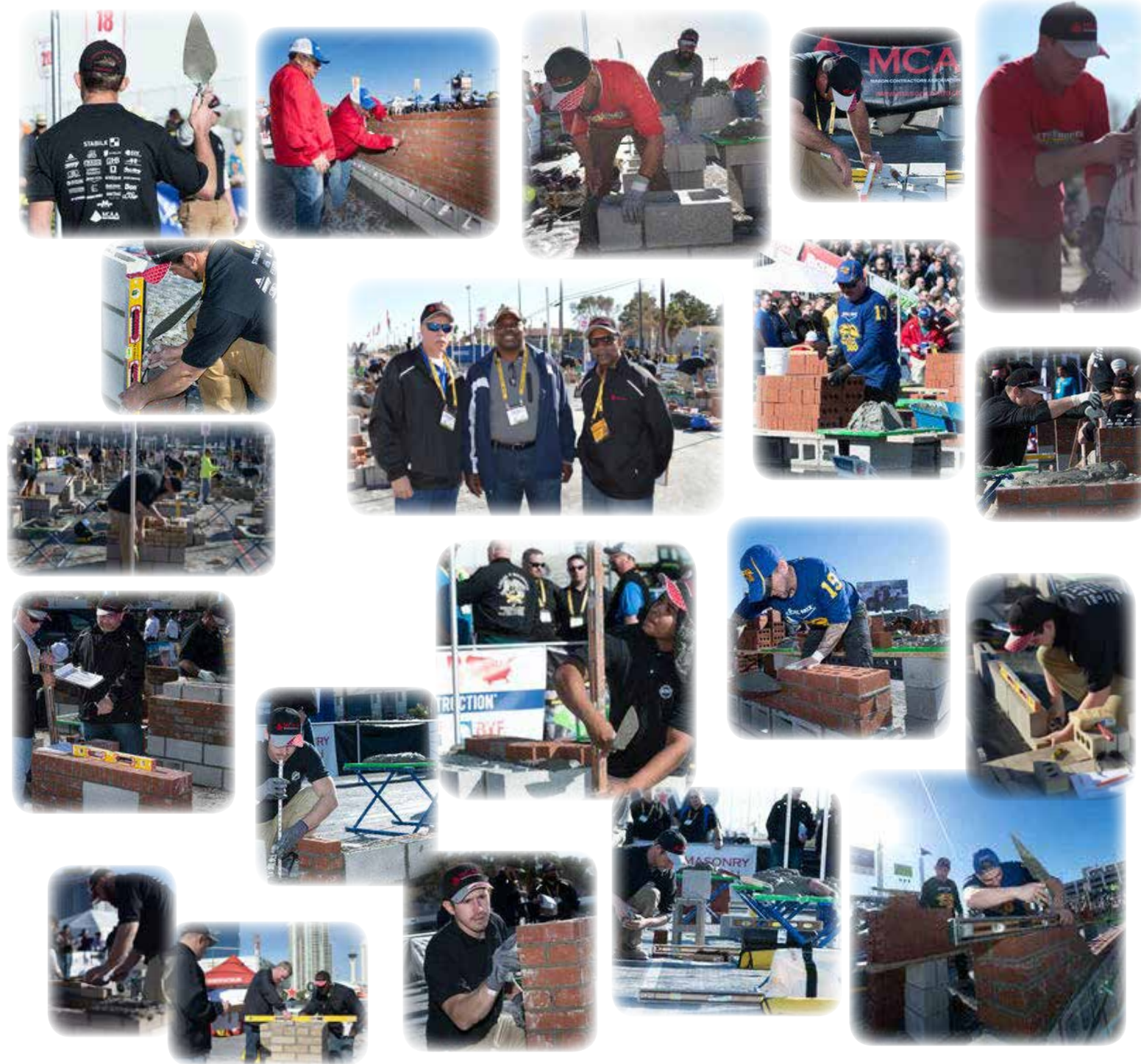

National Masonry Instructors Association would like to congratulate Ryan Shaver on his new position as Workforce Development and Training Coordinator for NCMCA and new SkillsUSA National Masonry Competition Chairman.

## 2017 National Masonry Instructors Association Hall of Fame Inductees



Michael Shepherd

John Bongiovanni  
Accepting for his father

James Wilson

## Cade Masonry Products

Owner: Calvin Cade  
843-601-7359

Home of the  
"Plumb Device"

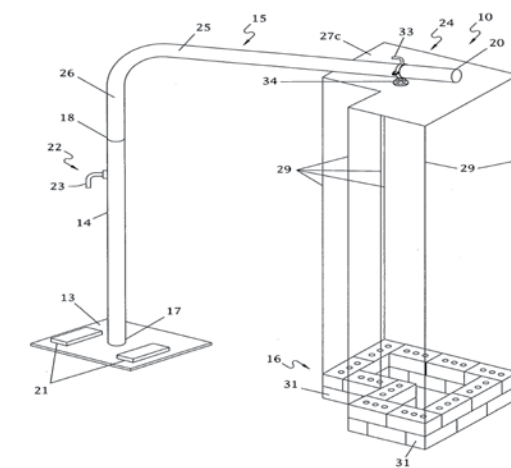

Fig. 12

The Plumb Device is used for constructing free standing Columns!

# Student Spotlight



from within the company. The tasks included blueprint reading classes, safety meetings, documentation of the jobs, and many other items involved in running a project. It also involved running a yard, which included all of the equipment needs, clean-up of jobs, etc. Curtis loved that job, but the economy in the first part of the 90's was on a downward trend, which hurt the company. He ended up going back in the field as a foreman.

In the summer of 1993, he was building the Lowes store in Salisbury, Md., when he received a phone call from his masonry teacher, telling him that the masonry instructor position was open at his old school. He applied, did two interviews, one of which was with his former principal. He was selected out of eight other candidates. The toughest thing about taking the position was telling Henry J. Knott that he was leaving his company. He said he understood and wished Curtis the best of luck and if it didn't work out, Curtis was always welcome to come back. They are still very good friends today, and Curtis tries to send him some of his students whenever he can.

After taking the masonry instructors position, he attended his first Masonry Showcase in Charlotte in 1995. It was very impressive and he knew he had to get involved. Curtis received a phone call from a young lady about judging the Masonry Skills Challenge in Tampa, Florida. It was a great honor to be asked to judge. This is when he met some great gentlemen, who were also masonry instructors. Mr. Milton Young and Mr. Eugene Johnson were talking about the National Masonry Instructors Association (NMIA) and suggested Curtis should join. He did. This organization is more like family than just peers. Curtis has had the privilege serving as President of the National Masonry Instructors Association for 5 years, and is now Treasurer. He will always be the NMIA spokesperson.

One will never know where or what event Curtis will attend. He has spent his entire life both as a teen and as an adult, in this great field of masonry and will continue as long as the good Lord allows him to. His words to other instructors have always been, "GET INVOLVED, in whatever organization that can help you and your students be successful." There are no words or money that can put a price on watching a student succeed in industry, and Curtis is lucky enough to have many.

## NMIA Hall of Fame Members

### Instructors

Paul Ford  
 Jack Murphy  
 Calvin Gatlin  
 Bernard Hubbard  
 Jessie Grissom  
 William Hodge  
 Alonzo Lewis  
 Milton Young  
 Joe McMillian  
 Luther Hightower  
 James Ham  
 George Readon  
 Archie Crawford  
 James Alston  
 Buddy Combs

Richard McKnight  
 James Fryer  
 Morris Wilson  
 Jack Davis  
 Max Randolph  
 Willie Levette  
 Edward Mims  
 William Young  
 Andrew Fuller  
 Robert Campbell  
 James Wilson  
 Mike Shepard

### Industry

Butch Hardy  
 Billy Freeman  
 Sam McGee  
 Brian Light  
 Calvin Brodie  
 Paul LaVene  
 Sam McGee  
 Doug Drye  
 Bill Behie  
 Richard Rick Cummings  
 Donny Kirtley  
 Pete C  
 Al Herndon  
 Steve Fechino  
 Carl Bongiovanni, Sr

Students from the Center of Applied Technology North, Severn, Maryland participated as the Mud Slingers for the Spec Mix Bricklayer 500 Virginia Regional.